

Jancy JB2400 Bender

OPERATOR'S MANUAL

WARNING!

BEFORE USE, BE SURE EVERYONE USING THIS MACHINE READS AND UNDERSTANDS ALL SAFETY AND OPERATING INSTRUCTIONS IN THIS MANUAL.



EYE PROTECTION
REQUIRED



NEVER PLACE
FINGERS NEAR
MOVING PARTS



LINE VOLTAGE
PRESENT



MODEL #JB2400

Serial # _____

Date of Purchase _____

Jancy JB2400 Bender

Congratulations on your purchase of a Jancy Slugger pipe/tube bending machine. Slugger machines are designed to deliver years of dependable service. Please take a moment to complete and mail your warranty registration card. Doing so will validate your machine's warranty period and ensure prompt service if needed. Thank you for selecting a Slugger product from Jancy Engineering.

TABLE OF CONTENTS

IMPORTANT SAFETY INSTRUCTIONS	3
GROUNDING INSTRUCTIONS	5
POWER SUPPLY	5
EXTENSION CORDS	5
GETTING STARTED	6
OPERATING INSTRUCTIONS	7
TURNING ON THE POWER	7
FORM DIE ASSEMBLY INSTALLATION	7
PRESSURE DIE ASSEMBLY INSTALLATION	7
MAKING A BEND	8
MAINTENANCE & TROUBLESHOOTING	9
APPENDIX A: BEND QUALITY AND TROUBLESHOOTING	10
APPENDIX B: COMMON PIPE AND TUBE BENDING TERMS	11
PARTS BREAKDOWN	12
PARTS LIST	14
MAINTENANCE RECORDS	15

LIMITED WARRANTY

Jancy Engineering Inc. will, within eighteen (18) months from the date of purchase, repair or replace any goods found to be defective in material or workmanship, provided the product warranty registration card has been returned to Jancy Engineering Inc. within thirty (30) days of purchase date. This warranty is void if the item has been damaged by accident, neglect, improper service, or other causes not arising out of defects in materials or workmanship. This warranty does not apply to machines and/or components which have been altered, changed, or modified in any way, or subjected to use beyond recommended capacities and specifications. Electrical components are subject to respective manufacturers' warranties. All goods returned defective shall be returned prepaid freight to Jancy, which shall be the buyer's sole and exclusive remedy for defective goods. In no event shall Jancy Engineering be liable for loss or damage resulting directly or indirectly from the use of merchandise or from any other cause. Jancy Engineering is not liable for any costs incurred on such goods or consequential damages. No officer, employee, or agent of Jancy is authorized to make oral representations of fitness or to waive any of the forgoing terms of sale and none shall be binding on Jancy.

**JANCY ENGINEERING RESERVES THE RIGHT TO MAKE
IMPROVEMENTS AND MODIFICATIONS TO DESIGN WITHOUT PRIOR NOTICE.**

IMPORTANT SAFETY INSTRUCTIONS



WHEN USING ELECTRIC TOOLS, BASIC SAFETY PRECAUTIONS SHOULD ALWAYS BE FOLLOWED TO REDUCE THE RISK OF FIRE, ELECTRIC SHOCK, AND PERSONAL INJURY.

READ AND SAVE ALL INSTRUCTIONS FOR FUTURE REFERENCE.

1. **Keep Work Area Clean**
 - Cluttered areas and benches invite injuries.
2. **Consider Work Area Environment**
 - Do not expose power tools to rain.
 - Do not use power tools in damp or wet locations.
 - Keep work area well lit.
 - Do not use tool in presence of flammable liquids or gases.
3. **Guard Against Electric Shock**
 - Prevent body contact with grounded surfaces. For example: pipes, radiators, ranges and refrigerator enclosures.
 - Disconnect from power source when not in use.
 - Never use if electrical cord is damaged or wet.
 - Always keep electrical cord clear of rotating parts and belt while in motion.
4. **Keep Children Away**
 - Do not let visitors contact tool or extension cord.
 - All visitors should be kept away from work area.
5. **Dress Properly**
 - Do not wear loose clothing or jewelry. They can be caught in moving parts.
 - Non-skid footwear is recommended when working outdoors.
 - Wear protective hair covering to contain long hair.
6. **Use Safety Glasses**
 - Also use face or dust mask if cutting operation is dusty. Everyday eyeglasses only have impact resistance lenses, they are NOT safety glasses.
7. **Wear a Dust Mask**
 - Some dust created by grinding activities contains chemicals known to cause cancer, birth defects or other reproductive harm. Provide adequate ventilation.
8. **Keep All Guards in Place**
 - Keep all guards in place and in working order.
9. **Avoid Contacting Moving Parts**
10. **Secure The JB2400 Bender**
 - Lock the casters and chock the wheels to prevent machine from moving when in use.
11. **Before Servicing**
 - Disconnect the power supply before servicing the machine.

IMPORTANT SAFETY INSTRUCTIONS

12. **Reduce The Risk of Unintentional Starting**
 - Make sure switch is in the off position before plugging in.
13. **Never Leave Tool Running Unattended**
 - Turn power off. Don't leave tool until it comes to a complete stop.
14. **Handle Work Material with Caution**
 - Wear leather gloves when handling work pieces. Sharp edges and burrs can cause personal injury.
 - Support long pieces of material through bend.
15. **Don't Force Tool**
 - It will do the job better and safer at the rate for which it was designed.
16. **Don't Over Reach**
 - Keep proper footing and balance at all times.
17. **Do Not Use Damaged Tooling**
 - Tooling that shows signs of wear or is damaged should be replaced before continuing use.
18. **Install Tooling in Correct Orientation**
 - Install Form Die Assembly with Clamp Arm towards long bending arm.
 - Install Pressure Die Assembly with bronze end towards clamping arm.
 - See diagram below (Figure #1, below).

Fig. 1



19. **Keep Jancy Bender Properly Maintained**
 - Ensure that sufficient hydraulic fluid is in the reservoir (at least 3.5 gallons of Mobile DTE 24 or equal, 100 SUS - 350 SUS at 100°F).
 - Inspect hoses and fittings for cracks and leaks. Repair or replace before operating machine.
 - Grease main pivot assembly after every 40 hours of use.
20. **Only Use Recommended Fluids and Accessories**
 - Use only approved fluids and lubricants on this machine (refer to page 9).
 - Consult the owner's manual for recommended accessories. The use of improper accessories may cause injury to persons.

IMPORTANT: KEEP THESE INSTRUCTIONS FOR FUTURE REFERENCE

GROUNDING INSTRUCTIONS

WARNING!

Improperly connecting the grounding wire can result in the risk of electrical shock. Check with a qualified electrician if you are in doubt as to whether the outlet is properly grounded. Never remove the grounding prong from the plug. If the cord or plug is damaged, have it repaired before using. If the plug does not fit the outlet, have the proper outlet and/or plug installed by a qualified electrician. The Jancy Slugger Bender must be plugged into an appropriate outlet, properly installed in accordance with all codes and ordinances. The plug and outlet should look like those in Figure A.

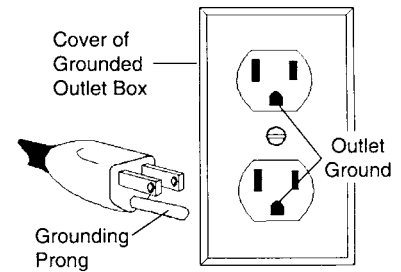

Fig. A

POWER SUPPLY

This machine is designed to run on either 110 or 220 volts. Operating this machine on voltage other than that stated on the machine will increase the risk of fire, and/or personal injury.

110 Volt machines must be plugged into a circuit that is controlled by a minimum 25 Amp circuit breaker.

220 Volt machines must be plugged into a circuit that is controlled by a minimum 15 Amp circuit breaker.

Failure to use the minimum rated circuit breakers will increase the risk of fire, and/or personal injury.

EXTENSION CORDS

Use only 3-wire extension cords, that have 3-prong grounding-type plugs and 3-pole receptacles that accept the machine's plug. Replace or repair damaged cords before use. Make sure your extension cord is in good condition. When using an extension cord, be sure to use one heavy enough to carry the current your product will draw. An under-sized cord will cause a drop in line voltage resulting in loss of power and overheating the machine. Jancy recommends using a minimum **12 gauge extension cord not to exceed 50 feet**.

OPERATING INSTRUCTIONS (BEFORE YOU BEGIN)

Remove all contents from packaging and inspect to ensure no damage was incurred during shipping. Your JB2400 package should also include the following:

DESCRIPTION	PART #	QTY
OPERATOR'S MANUAL	LIT115	1
5/8" ALLEN WRENCH	0070092	1
3/32" ALLEN WRENCH	0070093	1
JANCY WHITE GREASE	JB0810	1
PRESSURE DIE CAM CONTROL HANDLE	0151333	2

Additional Jancy White Grease in a can can be purchased by the can (#JB0810) or 12 can case (#JB0811)

GETTING STARTED

CAUTION!

ALWAYS DISCONNECT JANCY SLUGGER BENDER FROM POWER SOURCE BEFORE MAKING ADJUSTMENTS.

 **WARNING: Ensure the Jancy Slugger Bender switch is in the off position before plugging in the power lead to the power outlet. Ensure the power cable is not in a position where it can come into contact with any moving parts of the Jancy Slugger Bender.**

 **WARNING: Jancy Bender weighs approximately 600 pounds, use care in handling machine.**

 **WARNING: Do not insert forks into cabinet to load or unload the machine. Doing so may cause damage to machine components.**

- Remove all packaging material and shipping bands that secure the machine to the pallet.

There are two methods for removing the machine from the shipping pallet.

Method #1 (preferred method):

Remove the two 2X6 support boards from under the machine by removing the screws at both ends.

With some assistance, raise the machine slightly to remove the remaining two 2X6 boards.

If possible, build a ramp at the front of the machine.

With some assistance, roll the machine off of the pallet using caution not to drop it to the ground or onto anyone's feet or hands.

Method #2:

Lift machine off of pallet by using a forklift, or overhead lift, etc.

Position a single lifting strap around the upper box tube at the front end of the machine (as pictured).

ONLY RAISE THE MACHINE HIGH ENOUGH TO REMOVE THE PALLET, SET THE MACHINE ON THE GROUND AS SOON AS POSSIBLE.

Alternatively: Remove the two middle 2X6 boards from under the machine by removing the screws at both ends. Position the forks under the lower frame. Only lift the machine high enough to remove the shipping pallet.



Attach lifting strap as pictured

Have a qualified electrician install the appropriate power connector to the end of the power cord.

OPERATING INSTRUCCIONES

The Jancy Bender is designed to accommodate a wide variety of tube and pipe diameters and wall thicknesses. To ensure a quality bend, use the appropriate sized tooling for the material being bent. Example: 1.50" pipe is 1.90" OD, where as 1.50" tube is 1.50" OD. In most cases a Center Line Radius (CLR) of three (3) times that of the outer diameter should be used. See Appendix A of more information on bend quality and troubleshooting.

The Jancy Bender is fitted with a lockable master switch. It is recommended that the switch is locked when not in use to prevent untrained or unauthorized use of the machine.

Turning on the power

- Rotate the main power switch handle clockwise to the "ON" position.
- To turn the machine off, rotate the handle counter clock-wise to the "OFF" position.

Form die assembly installation



The forming dies can be extremely heavy. Use assistance or mechanical means to lift the larger form dies into position.



Do not drop the form dies, damage to the machine and/or personal injury may result.

- Install form die over the central locating pin.
- Rotate die until all of the smaller drive pins are engaged, lower form die completely.

Pressure die assembly installation

- Remove the pressure die pull handle.
- Position the pressure die assembly in the opening of the pressure die pivot, with the bronze pressure die towards the clamp arm. Insert pull handle into the pressure die pivot assembly.
- To re-position pressure die pivot assembly, loosen and remove the three (3) 3/4-10 SHCS that hold the pressure die base to the upper bending arm.
- Insert test material into the clamp arm, and rotate the pressure die assembly into place.
- With the "cam" handle in the full rearward position, position the pressure die assembly approximately 1/4" - 3/8" from the form die.
- Locate the threaded holes in the upper bending arm just behind the bolt holes in the pressure die base. Position the pressure die pivot assembly over these holes and install and tighten the two (2) 3/4-10 x 1.50" SHCS. Insert the 3/4-10 x 7.50" SHCS into the "cam" assembly, do not tighten yet.
- Rotate the "cam" assembly until the pressure die barely touches work piece, but allows the pressure die assembly to be swung out of position. Tighten the 3/4-10 x 7.50" SHCS.

MAKING A BEND

⚠ WARNING: Before powering up the machine, ensure that all moving parts are clear of obstructions, all bolts have been secured, and that the control lever is in the center/neutral position.

- Ensure that the appropriate tooling is installed for the bending material.
- Turn main power on.
- Spray pressure die with white lithium based aerosol spray lubricant such as Jancy White Grease (#JB0810/#JB0811).
- Insert material into the clamp arm, aligning the zero mark on the form die and the beginning of the bend.
- Rotate the pressure die assembly into position, adjusting the “cam” as necessary (see above section on pressure die assembly installation).
- To make a bend, slowly raise the control handle to the upper position.
- Release the handle at the desired bend angle, taking into account the “spring back” of the material.
- Releasing the handle will return the lever to the center/neutral position and stop all bending/retracting motion.
- To retract the arms and reset the machine for the next bend, lower control lever to the down position, holding it there until the arms are fully retracted.
- Rotate the pressure die assembly out of the way and remove the material.
- It may be necessary to tap on material with a mallet to dislodge it from the form die.

For repeatable bends:

This Jancy Slugger Pipe/Tube bender is equipped with a limit switch system to allow for repeatable bending.



To set up the machine for repeatable bends using test bend material:

- Thread micro adjusting collar half way onto the macro collar
- Make a test bend to the desired angle taking into account the “spring back” of the material.
- At the desired angle, loosen the macro collar fixing screw and slide the assembly towards the limit sensor. Tighten the macro collar fixing screw when the light on the sensor comes on.

To set up the machine for repeatable bends using the preset gauge:

- Estimate the amount of “spring back” for the material being bent.
- Add this amount to the desired bend angle, this is the “adjusted bend angle”.
- Loosen the macro collar fixing screw and slide the assembly towards the limit sensor.
- Tighten the fixing screw at the adjusted bend angle on the “PRESET BEND TO ANGLE” gauge.
- Adjust the micro adjustment collar to fine tune the bend angle during test bending.

For best results and consistent repeatable bends, develop a routine for making the bend.

- Load the material in the same manner.
- Rotate the pressure die assembly into the same position.
- Do not adjust the “cam” or adjusting collars, once acceptable bends have started.

Once finished with the limit switch, return the adjusting collars to the most rearward position. This will prevent the sensor system from being triggered accidentally.

MAINTENANCE

In order to keep your Jancy Bender in top working order, it is necessary to follow the maintenance schedule below.

Every use: Inspect machine for damage (i.e. cracked hoses, leaking fittings, etc.).

Every month (40 hours of use): Inject grease into grease fittings at main pivot assembly.

Every year: Drain hydraulic fluid and replace with at least 3.5 Gal. of fresh/clean Mobile DTE 24 or equal (100 SUS to 350 SUS at 100 oF).

JB2400 Voltage Conversion

See instruction sheet 0111DOC for complete instructions and diagrams for voltage conversion.

TROUBLESHOOTING

Problem:

Machine does not switch on

Machine stops working

Nothing happens when control lever is moved

Inconsistent bend angles

Wrinkles on internal surface of bend

Excessive ovalization

Necking of material at beginning and end of bend

Solution:

- 1) Check plug/power cord.
- 2) Check power distribution panel and circuit breaker.

- 1) Machine overload.
- 2) Material is too much for machine.
Turn off machine, let it sit for a few seconds, then switch back on.
- 3) Move control lever to the down position to release material.

Bend angle limit switch engaged, move adjusting collars away from sensor.

Incorrect "adjusted" bend angle used, adjust "springback" amount.

- 1) Pressure die and form die may be touching
- 2) Form die radius is too small for material, refer to chart for correct former.

Worn pressure die, rotate or replace die.

Pressure die "grabbing" material, spray pressure die with spray grease.

TROUBLESHOOTING

Appendix A: Bend Quality and Troubleshooting

Minimum Center Line Radius Guidelines

Tube Diameter	Tube Wall Thickness									
	0.039	0.047	0.059	0.079	0.098	0.118	0.128	0.138	0.157	0.177
0.250	1	1	1	1	N/A	N/A	N/A	N/A	N/A	N/A
0.375	1	1	1	1	1	1	1	1	1	1
0.500	1.5	1	1	1	1	1	1	1	1	1
0.625	2	2	2	1.5	1.5	1.5	1.5	1.5	1.5	1.5
0.750	2.5	2.5	2.5	2	2	2	2	2	2	2
0.875	3	3	2.5	2	2	2	2	2	2	2
1.000	3.5	3.5	3	2.5	2.5	2.5	2.5	2.5	2.5	2.5
1.125	3.5	3.5	3.5	3	2.5	2.5	2.5	2.5	2.5	2.5
1.250	4.5	4.5	4.5	3.5	3	3	3	3	3	3
1.375	4.5	4.5	4.5	3.5	3.5	3.5	3.5	3.5	3.5	3.5
1.500	7.5	6	5.5	4	4	3.5	3.5	3.5	3.5	3.5
1.625	7.5	6	5.5	4	4	3.5	3.5	3.5	3.5	3.5
1.750	N/A	N/A	6.5	5.5	5	4	4	4	4	4
1.875	N/A	N/A	7.5	6	5	4	4	4	4	4
2.000	N/A	N/A	7.5	7.5	6	5	5	5	5	5
2.125	N/A	N/A	7.5	7.5	6	5.5	5.5	5.5	5.5	5.5
2.250	N/A	N/A	N/A	7.5	6	5.5	5.5	5.5	5.5	5.5
2.375	N/A	N/A	N/A	7.5	6	6	6	6	6	6
2.500	N/A	N/A	N/A	7.5	6	6	6	6	6	6

Pipe Size	Pipe Wall Thickness			
	Sch 5	Sch 10	Sch 40	Sch 80
0.25	N/A	1.5	1.5	N/A
0.375	N/A	2.5	1.5	N/A
0.5	3	2.5	2	2
0.75	3.5	3	2.5	2.5
1	4.5	3.5	2.5	2.5
1.25	5.5	4	3	3
1.5	7	6	4	N/A
2	7.5	6.5	6	N/A

Appendix B: Common Pipe and Tube Bending Terms

Arc: The curved portion of tube or pipe bends. See Pipe Bending Diagram.

Centerline Radius (CLR): Distance in inches from the center of curvature to the centerline axis of the tube or pipe bends. See Diagram.

Cold Tube Bending: The bending of pipe or shapes by cold working methods.

Degree: Angle in degrees to which the pipe bends are formed (i.e. 45 degrees, 90 degrees, 180 degrees, etc.) See Pipe Bending Diagram.

Easy Way (EZ): Bending of a rectangular tube with its short side in the plane of the bend.

Grade: Manufacturers' specification of material types of pipe or tubes, (i.e. A53B, T304W SS).

Hard Way (HW): Bending of a rectangular tube with its long side in the plane of the bend.

I.D.: Inside diameter of the tube or pipe.

Minimum Tangent: The minimum straight length at the end of a pipe bends required by the bending machine to form a bend.

Neutral Axis (N-axis): That portion of the pipe or tube that is neither in compression or tension.

O.D.: Outside diameter in inches of the tube or pipe.

Out of Plane: The deviation in the horizontal plane of a single pipe bend between its tangent points, based on the theoretical center-line of the bend.

Ovality: The distortion or flattening of pipe or tube from its normal, round shape caused by the pipe bending process.

Roll Past: Small amount of arc bent beyond a specified degree, used to overcome spring back.

Spring Back: The amount a pipe is "unbent" when bending pressure is released.

Tangent: The straight portion of material on either side of arc of pipe bends. See Pipe Bending Diagram.

Tangent Point: The point at which the bend starts or ends. See Pipe Bending Diagram.

Wall: The thickness of bending material, difference between O.D. and I.D. divided by 2. $(O.D. - I.D.) / 2$ (usually in Inches)

Wrinkles: Waving or corrugation of pipe bends in the inner radius.

90 Degree Pipe Bends

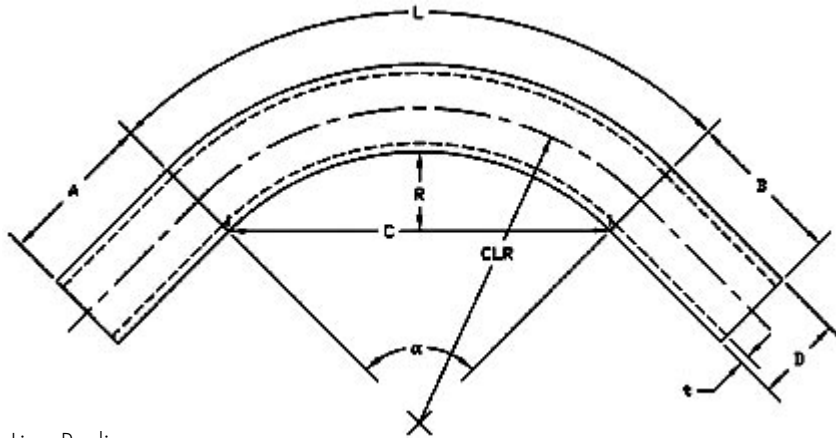

Legend

CLR= Center Line Radius
 α = bend angle
 L = Arc length (outside)
 R = Rise (inside)
 D = Tube outside diameter
 t = Tube wall thickness
 A= First tangent length
 B= Ending tangent length

Offset Pipe Bends

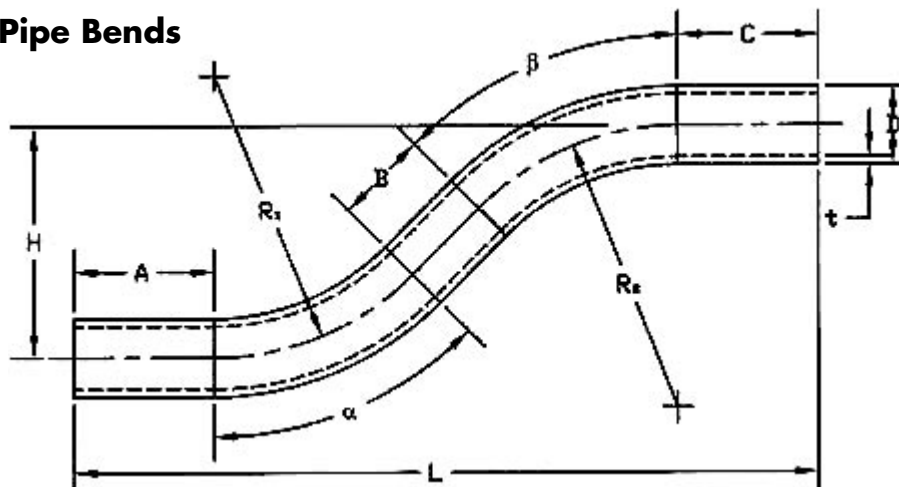

Legend

α = First bend arc angle
 β = Second bend arc angle
 A = First tangent
 B = Straight between bends
 C = Second tangent
 D = Tube outside diameter
 H = Height of offset
 L = Length of offset
 R_1 = First radius (CLR1)
 R_2 = Second radius (CLR2)
 t = Tube wall thickness

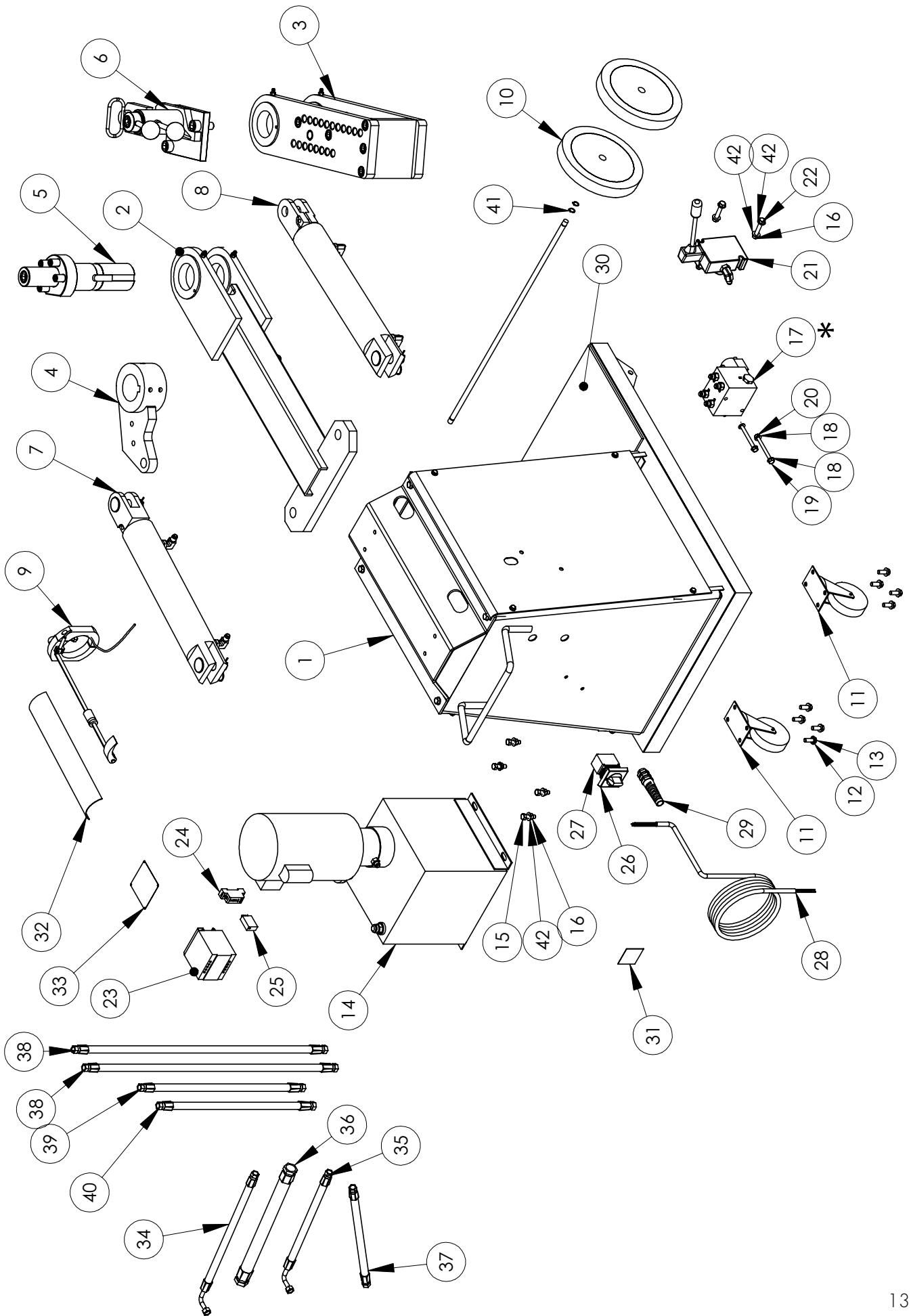

PARTS LIST

ITEM	PART #	DESCRIPTION	QTY
1	JBL24610	BASE CABINET ASSY.	1
2	JBL24605	JB2400 CENTRAL SUPPORT TUBE	1
3	JBL24604	RIGHT SIDE BENDING ARM	1
4	JBL24601	LEFT SIDE BENDING ARM	1
5	JBL24602	FORM DIE DRIVE ASSY.	1
6	JBL24603	PRESSURE DIE PIVOT CAM ASSY.	1
7	JBL24621	HYDRAULIC CYLINDER AND FITTINGS	1
8	JBL24621	HYDRAULIC CYLINDER AND FITTINGS	1
9	JBL24612	LIMIT SWITCH ASSEMBLY	1
10	JBL24217	WHEEL, 8 X 2 X 1/2"	2
11	JBL24218	CASTER, 4.0" SWIVEL ALL-LOCK	2
12	JBL26163	WASHER, FLAT 5/16" SAE	8
13	JBL26171	SCR, HHCS 5/16-18 X 1.00	8
14	JBL24622	PUMP/MOTOR ASSY. W/ FITTINGS	1
15	JBL26161	SCR, HHSC 3/8-16 X 1.25	4
16	JBL26167	NUT, 3/8-16	6
17*	JBL24618	MANIFOLD ASSY.	1
18	JBL26163	WASHER, FLAT 5/16"	4
19	JBL26159	SCR, HHCS 5/16-18 X 3.50	2
20	JBL26166	NUT, 5/16-18	2
21	JBL24619	CONTROL LEVER ASSEMBLY	1
22	JBL26162	SCR, HHCS 3/8-18 X 2.25	2
23	JBL24151	24V POWER SUPPLY W/ 110/220V RELAY	1
24	JBL26106	RELAY BASE, DIN MOUNT	1
25	JBL26105	24V RELAY	1
26	JBL26102	HANDLE DOOR MOUNT DISCONNECT	1
27	JBL26101	DOOR MOUNT DISCONNECT	1
28	JBL26100	POWER CORD	1
29	JBL26103	STRAIN RELIEF	1
30	JBL24319	V-GROOVED VINYL MAT	1
31	JBL26132	SERIAL NUMBER PLATE	1
32	JBL24132	BEND ANGLE STICKER	1
33	JBL26131	JANCY LOGO, MADE IN THE USA	1
34	JBL26113	HOSE, HYDRAULIC 6M3KMC-6FJX-6FJX90M-16	1
35	JBL26116	HOSE, HYDRAULIC 6M3KMC-6FJX-6FJX-13	1
36	JBL26112	HOSE, HYDRAULIC 12G1MC-12FJX-12FJX-14	1
37	JBL26111	HOSE, HYDRAULIC 6M3KMC-6FJX-6FJX-14	1
38	JBL26117	HOSE, HYDRAULIC 6M3KMC-6FJX-6FJX-30	2
39	JBL26114	HOSE, HYDRAULIC 6M3KMC-6FJX-6FJX-19	1
40	JBL26115	HOSE, HYDRAULIC 6M3KMC-6FJX-6FJX-18	1
41	JBL26151	RETAINING RING, EXT 1/2" HEAVY DUTY	2
42	JBL26164	WASHER, FLAT 3/8" SAE	8

*JBL26129 110V Coil, JBL26130 220V Coil

YOUR DISTRIBUTOR



Tel · 563.391.1300 or Fax · 563.391.2323
2735 Hickory Grove Road · Davenport, Iowa 52804
email · jancy@jancy.com / web · jancy.com